

# INOX | Upright Cabinets

REFRIGERATED CABINETS ▶ GN2/1-NO FROST ▶ CHILLER

## GRC 1850



### DETAILS

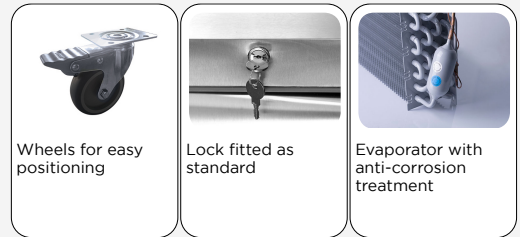

### GENERAL FEATURES

- GN2/1 Refrigerated upright cabinet
- Stainless Steel exterior and interior
- Ventilated Cooling
- Automatic compressor cycle defrost
- Evaporator and condenser with anti-corrosion treatment
- Foaming Agent Cyclopentane (70mm per side)
- Digital Thermostat
- Removable Gasket
- Lock fitted as standard
- Door with self closing (Not reversable)
- Adjustable shelves GN2/1: N.12 Pcs
- N.6 Wheels for easy positioning
- Energy efficiency class: D

### TECHNICAL SPECIFICATIONS

Capacity	1900 L
Temperature	-2°C ~ +8°C
Consumption	4.5 kWh/24h
Rated Power	945 W
Noise level	43 dB(A)
Net Weight	270 Kg
Gross Weight	289 Kg
External Dimensions (WxDxH mm)	2050x850x2075
Internal Dimensions (WxDxH mm)	1905x680x1560
Packaging dimensions (WxDxH mm)	2070x900x2170
Loading quantities 20'/40'/40'HQ	6/13/13

### PRODUCT DIMENSIONS

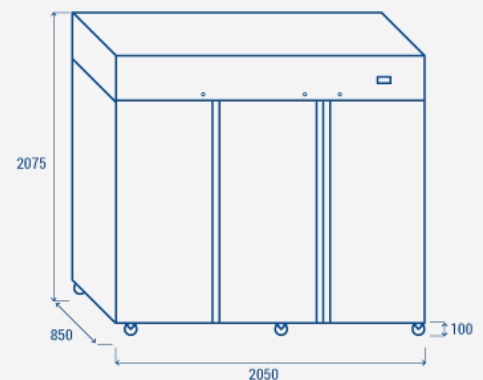

### CERTIFICATION

